

OXFORD | HOYER

Oxford[®]/Hoyer[®]

Arise/Ascend Lift

**Professional Series
SERVICE MANUAL**

 **SUNRISE
MEDICAL**
Long-Term Care

CONTENTS

Pages 3 - 4

Inspection Criteria of the Oxford/Hoyer Arise/Ascend

Page 5

Testing of the Oxford/Hoyer Arise/Ascend

Pages 6 - 13

Service and Maintenance Schedule for the Oxford/Hoyer Arise/Ascend

Page 14

Fault Finding on the Oxford/Hoyer Arise/Ascend

Page 15

Torque Settings for the Oxford/Hoyer Arise

Page 16

Torque Settings for the Oxford/Hoyer Ascend

Page 17

Exploded View of the Oxford/Hoyer Arise

Page 18

Parts List of the Oxford/Hoyer Arise

Page 19

Exploded View of the Oxford/Hoyer Ascend

Page 20

Parts List of the Oxford/Hoyer Ascend

Page 21

LOLER (UK only): Thorough Examination Report

Page 22

Blank Notes Page

INSPECTION CRITERIA

Sunrise Medical Ltd recommends a thorough inspection and test of the Oxford/Hoyer Arise/Ascend and its lifting accessories, slings etc. is carried out every six months. The examination and test should be conducted according to the recommendations and procedures below. Sunrise Medical Ltd recommends, authorised service dealers should carry out maintenance, inspection and certified testing only.

Note: These recommendations are in compliance with the requirements of 1998 No2307 Health and Safety: The Lifting Operations and Lifting Equipment Regulations 1998. (LOLER) *This is a UK regulation. Outside the UK please check your local requirements.*

SUPPORT ARM

Confirm the presence and security of the sling retainers on the sling hooks.
Check the sling hooks on the support arm for damage or wear.
Check for adequate padding on the support arm (no metal should be visible on the inside of the sling hooks).
Check for secure attachment of the arm to the mast pivot.
Make sure there is only minimal side movement of the arm and that it is free to rotate in the mast pivot.
Check the arm is in alignment with the centreline of the hoist.
Check the sling retaining bosses and clips on the actuator, mounting bracket for damage or excessive wear.
Check the security and for wear on the actuator unit, mounting pin and mounting bracket on the arm.
(Any excessive movement or play of the actuator, must be investigated).

MAST

Check for secure attachment of the handle bar to the mast.
Confirm the presence and the proper location of the mast engagement label.
Check the operation of the mast-locking device.
Make sure the mast fully engages onto the base socket.
Check for wear on the actuator unit mounting, mounting pin and mounting bracket on the mast.
(Any excessive movement or play of the actuator, must be investigated).

POWER PACK:

Check for secure attachment of the power pack mounting plate to the mast
Check for secure attachment of the power pack to the mounting plate
Check the function of the Emergency Stop button.
Check the hand control for correct functioning in both directions, i.e. lift and lower
Check the fit of the hand control plug and socket
Inspect the actuator plug for correct fitting.
Check the operation of the emergency raise and lowering function.

ELECTRIC LEG ADJUSTMENT:

Operate the leg opening buttons on the hand control and check the legs open and close correctly.
Check that the legs lock when the hand control button is released.

INSPECTION CRITERIA

KNEE PAD

Check for secure attachment of the kneepad to the mounting arms on the mast.
Check the kneepad is easily adjustable and tightened via the kneepad, locking knob.
Check the leg restraining straps for damage and wear i.e. fraying, loose stitching etc.
Check the condition of the upholstery for splits and or rips.

FOOT PLATE

Check for firm and secure fitment of the footplate to the cross member
Check the presence of the foot mats and their condition for wear or lack of grip

LEG PIVOTS

Check the leg pivots are secure and the legs pivot freely. Any stiffness must be investigated.
Make sure there is no excessive play in the leg pivots.

CASTORS

Check all castors for firm attachment to the legs.
Check for free rotation of the castor and the wheels.
Remove any build up of threads, hair or fluff.
Lubricate if necessary with a light mineral based grease.
Check correct operation of the brakes.

LIFT ACTUATOR

The actuator should require no maintenance.
Check for correct operation.
Check for correct operation of mechanical emergency lowering device.
Confirm anti-crush precautions are operational.
Listen for unusual noise.
Check for wear on the mounting boss top and bottom.
(Any excessive movement or play of the actuator must be investigated).

BATTERIES

The batteries in the power pack should not require maintenance, other than regular charging as detailed in the charging instructions.

CHARGING UNIT

Confirm the charger unit is charging the battery pack.
Check mains plug is fitted with the properly rated fuse.
Check the safety of the input and output lead wiring.

CLEANING

Clean with ordinary soap and water and/or any hard surface disinfectant. Harsh chemical cleaners or abrasives should be avoided as these may damage the surface finish of the lift. Avoid wetting any of the electrical parts.

TESTING

LOAD TEST

The load test should be carried out in accordance with the manufacturers test procedures. It is strongly recommended that, an authorised service dealer carry out the test.

Oxford/Hoyer Electric hoists have been designed to the requirements of:

1 BS EN ISO 10535 1998 Hoists for the transfer of disabled persons

The hoists are designed to lift the Safe Working Load only. The load lifting capability is set electronically and must not be increased as this causes excessive loading when the actuator reaches the limits of travel. This will affect the actuator's useful life.

2 BS EN ISO 10535 Load Raising Test

This test is a straightforward lift of a load the equivalent to the Safe Working Load, from the lowest position to highest position of the hoist.

TEST LOADS – OXFORD/HOYER ARISE/ASCEND

170kgs/375lbs

The load test should be carried out in accordance with the manufacturers test procedures. It is strongly recommended that an authorised service dealer carries out, the test.

CERTIFICATION

An authorised service dealer will issue a test certificate after satisfactory completion of the thorough inspection and test.

This certificate will be valid for six months.

Thorough Examination Report

Lifting Operations and Lifting Equipment Regulations 1998 (LOLER UK ONLY)

LOLER requires certain information to be included on the report given to a customer after a thorough examination. The information can be found in Schedule 1 (page 56) in the LOLER L113 publication.

Sunrise Medical Ltd has prepared a Thorough Examination Report that includes all the required information a copy can be found on page 18.

Please feel free to use this as the basis of your own report.

SERVICE & MAINTENANCE

TOOLS REQUIRED

- 21mm A/F Spanner (*for the rear castors*)
- 17mm A/F Spanner (*for the front castors*)
- 19mm or ¾ inch A/F Spanner (*for the mast and support arm fixing bolts*)
- 9/16 inch A/F Spanner + ¼ Hex Key (*for the mast/boom pivot bolt*)
- 17mm A/F + 14mm Spanner (*for the sling/actuator retaining boss bolt*)
- ½ inch A/F Spanner + 3/16 Hex Key (*for the mast end lift and leg actuator bolts*)
- 4mm Hex Key (*for the screws on the handle bar base plate and all other fixings*)
- Medium Strength Thread lock (BLUE) Type

SUPPORT ARM

- 1** The support arm is a two piece assembly that is secured to the mast pivot by an arm pivot casting. The arm pivot casting is secured to the end of the arm by two hexagon headed bolts.
- 2** Remove the grey plastic covers from the bottom of the support arm .The covers are a push on fit. Remove the covers by gently levering a thin blade or screwdriver between the boom and the covers.
- 3** Check that the two M12 hexagon headed bolts, are **fully tightened to 15 Nm.**
- 4** Remove the end caps from the black sling retaining bosses on the arm to reveal securing set pin.
- 5** Check that the set pin is **fully tightened to 5 Nm.**
- 6** Examine the actuator mounting point. Without taking the mounting point apart check for signs of wear on the fulcrum pin. Check for excessive vertical and horizontal movement in the mounting. This will give a good indication of wear but if there is any doubt the assembly should be stripped down as follows:
- 7** Remove the set pin from the actuator bracket.
- 8** Examine the pin for signs of wear. The diameter of the fulcrum pin is 9.5mm. Reduction in diameter due to **wear must not exceed 1mm**, before replacement.
- 9** Remove the outer sleeve bush from the support arm bracket and actuator top while holding the actuator, carefully lower the actuator to the ground. (Take care not to loose the sling bosses and the sling retainers and nylon spacers on either side of the actuator on the inside wall of the boom).
- 10** Examine the outer sleeve bush for wear **this should not exceed 1mm.**
- 11** Examine the actuator mounting on the support arm for wear on the bore of the bracket **this should not exceed 2mm.**
- 12** Examine the actuator top for wear **this should not exceed 1mm.**
- 13** Examine the split bushes for wear this should not exceed 0.5mm.
- 14** Reassemble the actuator to the boom bracket by replacing the sleeve, plastic washers, sling bosses and the sling retainers set pin and nut.
- 15** **Tighten the nyloc nut to 5 Nm.**

SERVICE & MAINTENANCE

16 Replace the end caps for the sling bosses.

NOTE: Sunrise Medical recommends Nyloc nuts should always be replaced if undone.
ALWAYS torque fasteners to the correct setting.

SUPPORT ARM PIVOT

1 Check the pivot for lateral, vertical and horizontal play that would indicate excessive wear. **Signs of excessive wear must be investigated.** Play at the pivot point must not exceed 1 mm before replacement.

2 Remove the plastic SUNRISE logo covers from the pivot.

3 Check the Set pin is **tightened to 8 Nm.**

4 Replace the plastic SUNRISE logo covers from the Boom pivot.

REMOVAL OF THE SUPPORT ARM PIVOT

1 To remove the support arm pivot, it is advisable to first remove the two M12 bolts from the end of the arm, this will enable the pivot to be removed and replaced more easily.

2 Remove the grey plastic covers from the top of the boom .The covers are a push on fit. Remove the covers by gently levering a thin blade or screwdriver between the boom and the covers.

3 Remove the bolts and pull the arm away from the pivot.

4 The arm pivot, is held in place with a set pin.

5 Remove the pin.

6 Examine the pin for signs of wear. The diameter of the pin is 12.7mm. Reduction in diameter due to **wear must not exceed 1mm** before replacement.

7 Withdraw the outer sleeve bushing from the arm pivot (if you did not remove the two M12 bolts, hold the boom while doing this as it may fall forwards).

8 Inspect the sleeve for wear as per the fulcrum pin.

9 Remove the plastic bearing washers (2 off) from the pivot and examine for any wear or damage. Lateral movement at the pivot is most likely to be because of wear on the washers.

10 Remove and examine the arm pivot and the remaining mast pivot casting, the pivots internal bores and the holes in the mast in particular for wear or damage.

11 The bore and holes are 20mm in diameter; **wear should not exceed 1mm on diameter** before replacement.

RE-ASSEMBLING THE SUPPORT ARM PIVOT

1 After performing all the actions and checks listed under "**Removal of the support arm pivot**" (page 7) reassemble the support arm pivot as follows:

2 Lubricate the set pin and sleeve with any light mineral-based grease, or silicon spray, paying particular attention to the bearing washers, and the pivots internal bores.

SERVICE & MAINTENANCE

- 3** Insert one end of the outer sleeve into the hole on one side of the mast pivot.
- 4** Refit the arm pivot and one bearing washer into the top of the mast pivot.
- 5** Align the holes in the mast pivot, bearing washer and support arm pivot.
- 6** Insert the sleeve into the holes and ensure it passes into the mast pivot hole on the opposite side.
- 7** Pull back the sleeve until it is inside the pivot.
- 8** Insert the remaining bearing washer between the pivot and the inside of the mast pivot on the opposite side.
- 9** Line up the hole of the washer with the bores of the pivot and push the sleeve through the washer and into the mast pivot.
- 10** Insert the set pin into the sleeve including the steel washers and fasten the Nyloc nut.
- 11 Tighten to 8 Nm.**
- 12** Insert the arm pivot into the support and refit the 12mm bolts and M12 Nyloc nuts (See note below).
- 13 Tighten each bolt to 15 Nm.**
- 14** Replace plastic covers.

NOTE: Sunrise Medical recommends Nyloc nuts should always be replaced if undone.

NEVER fit a new pin or sleeve to a worn or damaged casting/component.

ALWAYS torque fasteners up to the correct setting.

MAST

- 1** Remove the grey plastic covers from the top of the mast. The covers are a push on fit. Remove the covers by gently levering a thin blade or screwdriver between the mast and the covers.
- 2** Check the two M12 hexagon headed bolts that hold the boom pivot casting, are **fully tightened to 15 Nm**.
- 3** Replace the grey plastic covers to the mast.
- 4** Check the socket headed counter sunk screws (4), which hold the push handle to the mast. With a 4 mm A/F Allen key confirm the screws are fully tightened to **5 Nm**.
- 5** Examine the actuator mounting point for damage or wear.
- 6** Without taking the mounting apart check for signs of wear on the set pin.
- 7** Check for excessive vertical and horizontal movement in the mounting. This will give a good indication of wear but if there is any doubt the assembly should be stripped down as follows:
- 8** Remove the set pin that secures the actuator to the mast bracket.
- 9** Examine the pin for signs of wear. The diameter of the set pin is 9.5mm. Reduction in diameter due to **wear must not exceed 1 mm** before replacement.

SERVICE & MAINTENANCE

- 10** Remove the outer sleeve bush from the mast bracket, and actuator-mounting boss while holding the actuator, carefully lower the actuator and boom to the ground.
- 11** Examine the outer sleeve bush for wear **this should not exceed 1mm.**
- 12** Examine the actuator mounting bracket on the mast, for wear on the bore of the bracket **this should not exceed 1mm.**
- 13** Examine the actuator bottom mounting boss for wear **this should not exceed 1mm.**

After performing all the actions and checks reassemble the actuator to the mast as follows:

- 1** Lubricate the Set pin and sleeve with any light mineral-based grease, or silicon spray paying particular attention to the, bearing washers, and the boom pivots internal bore.
- 2** Replace the pin and sleeve through the actuator and mast bracket.
- 3** Replace washer and nyloc nut **Tighten to 15 Nm.**
- 4** Confirm the presence and the proper location of the engagement label.
- 5** Check the mast is fully engaged as per the engagement label.
- 6** Check the engagement of the mast-locking knob.
- 7** Confirm the mast will lift from the mast socket when the locking knob is unscrewed.
- 8** Check the electric leg opening contact assembly, for secure fitment and damage or wear.

NOTE 1: It is most important set pin and sleeve assemblies are re-assembled carefully. Check to ensure complete security.

NOTE 2: Sunrise Medical recommends Nyloc nuts should always be replaced if undone.

NEVER fit a new pin or sleeve to a worn or damaged casting/component.

ALWAYS torque fasteners up to the correct setting.

BATTERY PACK & CONTROL UNIT

- 1** Confirm the mounting bracket is firmly attached to the mast. Three M6 cap head screws secure the mounting bracket. **Confirm the screws are fully tightened to 5 Nm.**
- 2** Check the engagement of the battery pack with the mounting. The battery pack should snap into place and be retained by a latch at the top of the pack. Make sure the latch is functioning correctly and holds the battery pack firmly in place.
- 3** Check the actuator, and hand control plugs are inserted fully into the appropriate socket on the base of the control unit. The plugs, particularly the hand control plug, are a tight fit in the sockets and must be pushed fully home. The hand control plug is indexed and can only be fitted in one position. The other plug is not indexed and can be fitted with a straight push.

SERVICE & MAINTENANCE

- 4** Inspect the hand control and coiled lead for any obvious signs of damage. Damage to the hand control and particularly to the lead can cause intermittent faults. The hand control should be replaced if damage is evident. The mounting hook on the rear top of the hand control, can be replaced by unscrewing two screws and fitting a new hook.
- 5** Check the operation of the hand control. Press the up and down buttons and confirm the boom moves in the proper direction.
- 6** Press the leg open and close buttons and confirm the legs move in either direction.
- 7** Check the operation of the Emergency stop switch. Push in the red button, this will latch and remain depressed and cut off all power to the lift.
- 8** Confirm by looking at the LCD panel that should now state the word STOP and show the image of a plug by the side of it and, by using the hand control.
- 9** Return power to the lift by twisting the red button clockwise and releasing. The LCD panel should no longer be showing the word STOP or the image of a plug and battery power should now be displayed instead.

Check the operation of the Emergency raise and descent buttons. These are small flush buttons on the front of the control unit under the Emergency stop switch labelled EMERGENCY and an up and a down arrow. The button is operated by pushing with a ballpoint pen or similarly shaped object.

CHARGER

- 1** Check the charger mains light is functional (Green light).
- 2** Check the engagement of the battery pack with the mounting. The battery pack should snap into place and retained by a latch at the top of the pack. Make sure the latch is functioning correctly and holds the battery pack firmly in place.
- 3** Check the charging light is functional when charging the battery (Amber light).
- 4** Check the condition of the mains lead for damage or loose wiring.

KNEE PAD

- 1** Examine the knee pad assembly is free from wear or damage.
- 2** Check for excessive vertical and horizontal movement in the assembly. This will give a good indication of wear but if there is any doubt the assembly should be stripped down as follows:
- 3** Remove the locking handle from the kneepad assembly.
- 4** Remove the spacer tube, the steel washer, and the nylon bearing washer.
- 5** Remove the steel rod that retains the Knee pad within the slots on the mast arms.
- 6** Examine the rod for damaged threads and wear on the Hexagon form on the rod **wear on the rod should not exceed 1mm.**
- 7** Examine the slots on the Knee pad, **the wear on the slots should not exceed 1mm.**

SERVICE & MAINTENANCE

Examine the bore on the mast arm assembly that houses the steel rod **the wear on the bore should not exceed 1mm.**

FOOT PLATE

- 1** Remove the footplate by lifting it up and away from the locating holes on the cross member.
- 2** Check the locating lugs on the bottom of the footplate for wear or damage.
- 3** Check the grip mats are not worn smooth and securely fixed to the footplate. Replace the foot plate via the lugs into the cross member.

CROSS MEMBER - LEGS / LEG PIVOT PINS

- 1** Check the leg pivots are secure and **tightened to 5 Nm**, and the legs pivot freely. Any stiffness must be investigated.
 - 2** Check that there is no excessive play in the leg pivots.
 - 3** Support the underside of the cross member so the front castors are off the floor and check the up and down movement of the leg. Movement in excess of 5mm is not acceptable and the pivot should be stripped down for closer inspection.
 - 4** Removal of the legs/leg pivots can be done, as follows.
 - 5** Remove the mast and boom assembly and set aside. Turn the lift base upside down and unscrew the 24 off M6 CSK head screws that secure the base plate to the cross member.
 - 6** Remove the base plate.
 - 7** To enable the leg pivot pin to be inspected, it will be necessary to remove the set pin that holds the piston end of the actuator in place on the cross member. Once the pin is removed the leg and the actuator can be lifted free from the cross member.
 - 8** Remove the leg and actuator taking care not to lose the bronze bearing washers at each end of the leg pivot pin.
- NOTE:** Support the actuator to prevent damage to the mounting point still attached to the leg. If any work is to be done on the leg, it is safer to remove the actuator.
- 9** The leg pivot pin can now be withdrawn and inspected.
 - 10** Clean the pin of any debris or replace the pin if worn.
 - 11** Inspect the leg pivot bush in the leg. Clean the bush in the leg of any debris or replace the leg if it is worn.

RE ASSEMBLY OF THE LEG PIVOT PINS

- 1** Lubricate the leg pivot pin with any light mineral-based grease, or silicon spray.
- 2** Place one of the bronze washers over the hole in the main base casting of the cross member.

SERVICE & MAINTENANCE

- 3** Refit the pin into the leg with the deeper shoulder of the pin going into the main base casting of the cross member.
- 4** Place the leg over the pivot.
- 5** Place remaining bronze washer over the leg pivot pin so that it rests on the surface of the leg bush.
- 6** Replace the set pin (**after applying threadlock**) that secures the actuator piston to the centre of the cross member and **tighten to 5 Nm**.
- 7** Replace the plates.
- 8** Apply loctite to the M6 CSK screws and **tighten them to 5 Nm**.
- 9** Ensure the leg actuators opens and closes the legs correctly.

NOTE: Before applying threadlock to any screw or bolt check it can be screwed into the component without hindrance from old remaining threadlock. This could affect the proper torque setting.

CROSS MEMBER - LEG ACTUATORS

To remove the actuators you will need to remove the base plate and leg assemblies as per the procedure listed under "**Cross member - legs / leg pivot pins**" (parts 4 to 7, page 11).

- 1** The set pins can now be removed from the leg end on the actuators.
- 2** Disconnect the bullet connectors on the wiring looms to remove the actuators from the hoist.
- 3** After inspection or replacement, reconnect the bullet connectors.
- 4** Refit the set pin and nyloc nut for the actuator on the leg end first and **tighten to 5 Nm**.
- 5** Replace the set pin (**after applying threadlock**) that secures the actuator piston to the centre of the cross member and **tighten to 5 Nm**.
- 6** Replace the plates.
- 7** Apply loctite to the M6 CSK screws and **tighten them to 5 Nm**.
- 8** Ensure the leg actuators opens and closes the legs correctly.

NOTE 1: Sunrise Medical recommends Nyloc nuts should always be replaced if undone.

NOTE 2: Before applying threadlock to any screw or bolt check it can be screwed into the component without hindrance from old remaining threadlock. This could affect the proper torque setting.

REAR CASTORS

- 1** Check the front and rear castors are firmly fixed to the legs. Remove any loose castors with a 21mm A/F Spanner, re-assemble with threadlock. **Tighten to 10 Nm**.

SERVICE & MAINTENANCE

2 Make sure the castors swivel and the wheels rotate freely. Remove any build up of threads, hair or fibres that may clog the bearings and prevent free rotation. Lubricate if necessary with a light, mineral based grease or silicon spray.

3 Check the action of the brakes on the rear castor. A foot-operated pedal activates the brake. Check the brake pedal locks in place and that the castor does not move when the brakes are engaged.

NOTE: Before applying threadlock to any screw or bolt check it can be screwed into the component without hindrance from old remaining threadlock. As this could affect the proper torque setting.

FRONT CASTORS

1 Check the front and rear castors are firmly fixed to the legs. Remove any loose castors with a 17mm A/F Spanner, re-assemble with Loctite or similar thread locking compound. **Tighten to 10 Nm.**

2 Make sure the castors swivel and the wheels rotate freely. Remove any build up of threads, hair or fibres that may clog the bearings and prevent free rotation. Lubricate if necessary with a light, mineral based grease or silicon spray.

NOTE: Before applying threadlock to any screw or bolt check it can be screwed into the component without hindrance from old remaining threadlock. As this could affect the proper torque setting.

FAULT FINDING

● Problem - Hoist not working

Possible Fault	Remedy
Emergency stop switch activated	Can be identified by a LCD panel that will have the word STOP and a picture of a plug in the panel. Turn red button clockwise or anticlockwise (try both) and release.
Flat batteries	Can be identified by a LCD panel that will have none of the four blocks illuminated (audible beep should have been heard prior to this)
Power supply disconnected (detachable battery packs)	Push battery into place until a CLICK can be heard
Completely flat batteries (discharged beyond recovery)	Replace batteries

● Problem - Hoist won't go up or won't go down

Possible Fault	Remedy
Hand control plug not fully engaged	Push plug firmly into socket (in an emergency use of the Emergency raise and lower function on the control box will suffice)
Wiring in hand control plug detached	Replace hand control + As above
Hand control switches not working	Replace hand control + As above
Wires detached inside handset	Replace hand control + As above
Hand control socket damaged	Replace control box
Relay on control board inoperative	Replace control box
Defective actuator	Replace actuator
Anti-crush micro switch activated (Safety Device)	Check for correct function of micro switch, or remove any obstacle that may have come between the boom as it was lowering
Actuator jack plug disconnected	Checkout plug and re-connect
Actuator socket damaged	Replace control box

● Problem - Electric Leg Operation not working (one or both legs not moving)

Possible Fault	Remedy
Leg opening plug disconnected	Re-connect
Actuator disconnected from leg or centre mounting	Re-assemble, replace mounting bolts
Actuator defective	Replace actuator
Power coupling in mast base defective	Replace coupling

TORQUE SETTINGS (ARISE)



The 2 bolts on battery bracket are torqued 5 Nm with threadlock

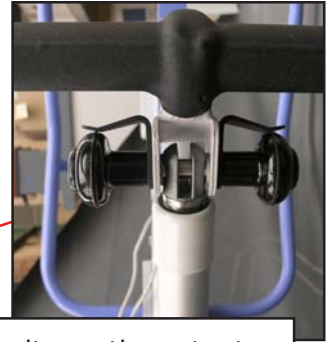

The 2 bolts on the actuator brackets (top & bottom) are torqued 5 Nm without threadlock

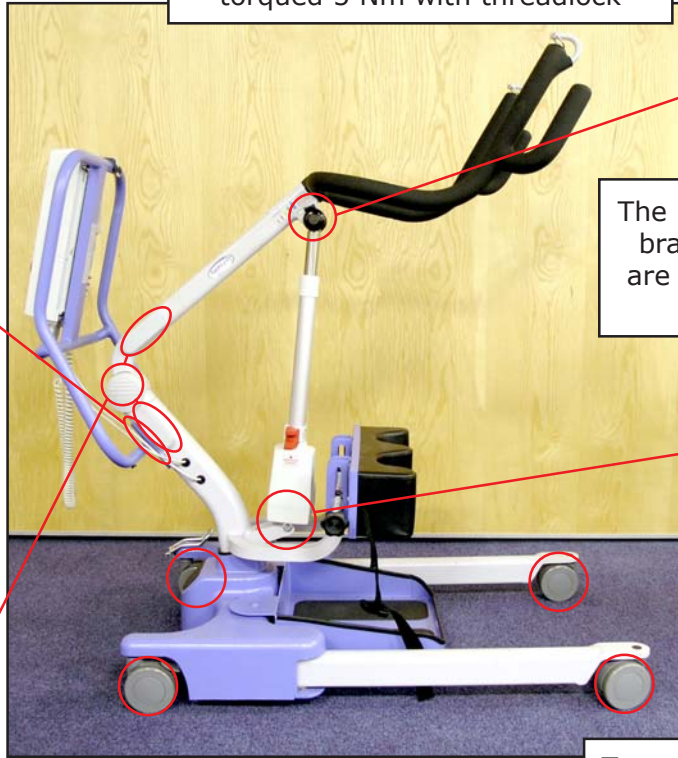

All 4 bolts on handle frame are torqued 5 Nm and with threadlock

Torque 8 Nm without threadlock



4 bolts with torque 15 Nm without threadlock

Torque 10 Nm on all 4 castor stems (front and rear) and with threadlock

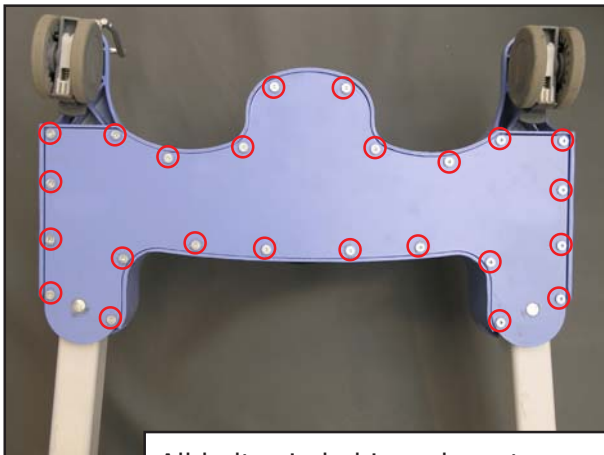

All bolts circled in red are torqued with 5 Nm with threadlock

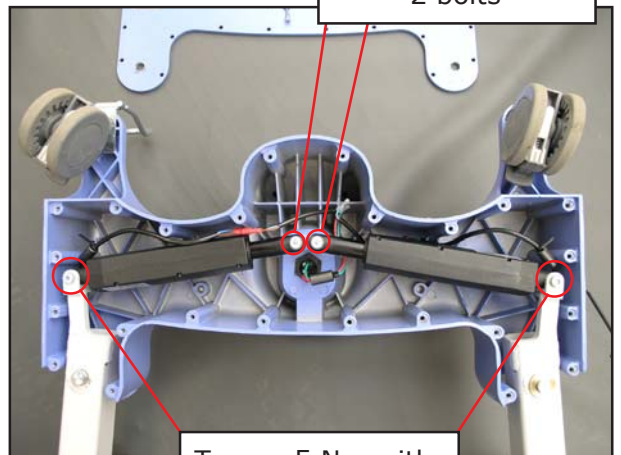

Torque 5 Nm with threadlock on these 2 bolts

Torque 5 Nm without threadlock on these 2 bolts

TORQUE SETTINGS (ASCEND)



All 4 bolts on handle frame are torqued 5 Nm and with threadlock

The 2 bolts on battery bracket are torqued 5 Nm with threadlock



The 2 bolts on the actuator brackets (top & bottom) are torqued 5 Nm without threadlock

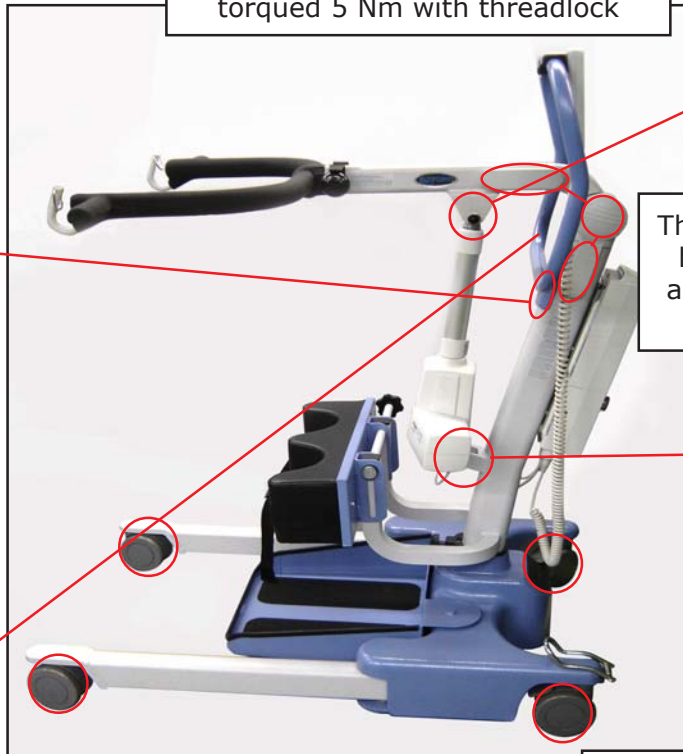

Torque 8 Nm without threadlock



Torque 10 Nm on all 4 castor stems (front and rear) and with threadlock

4 bolts with torque 15 Nm without threadlock

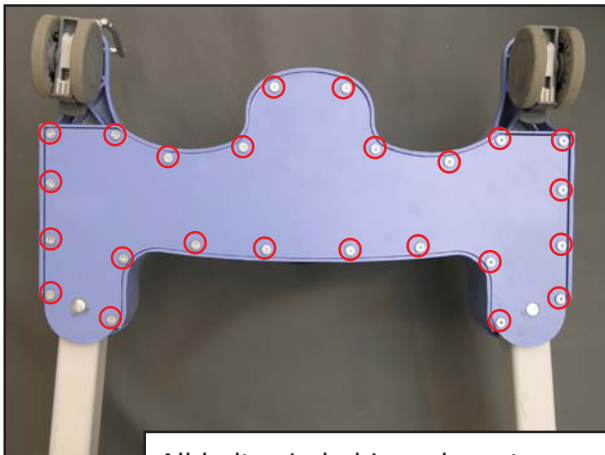

All bolts circled in red are torqued with 5 Nm with threadlock

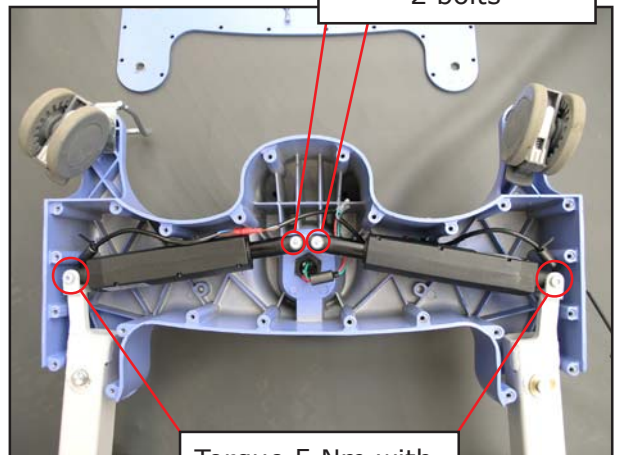

Torque 5 Nm with threadlock on these 2 bolts

Torque 5 Nm without threadlock on these 2 bolts

EXPLODED VIEW (ARISE)

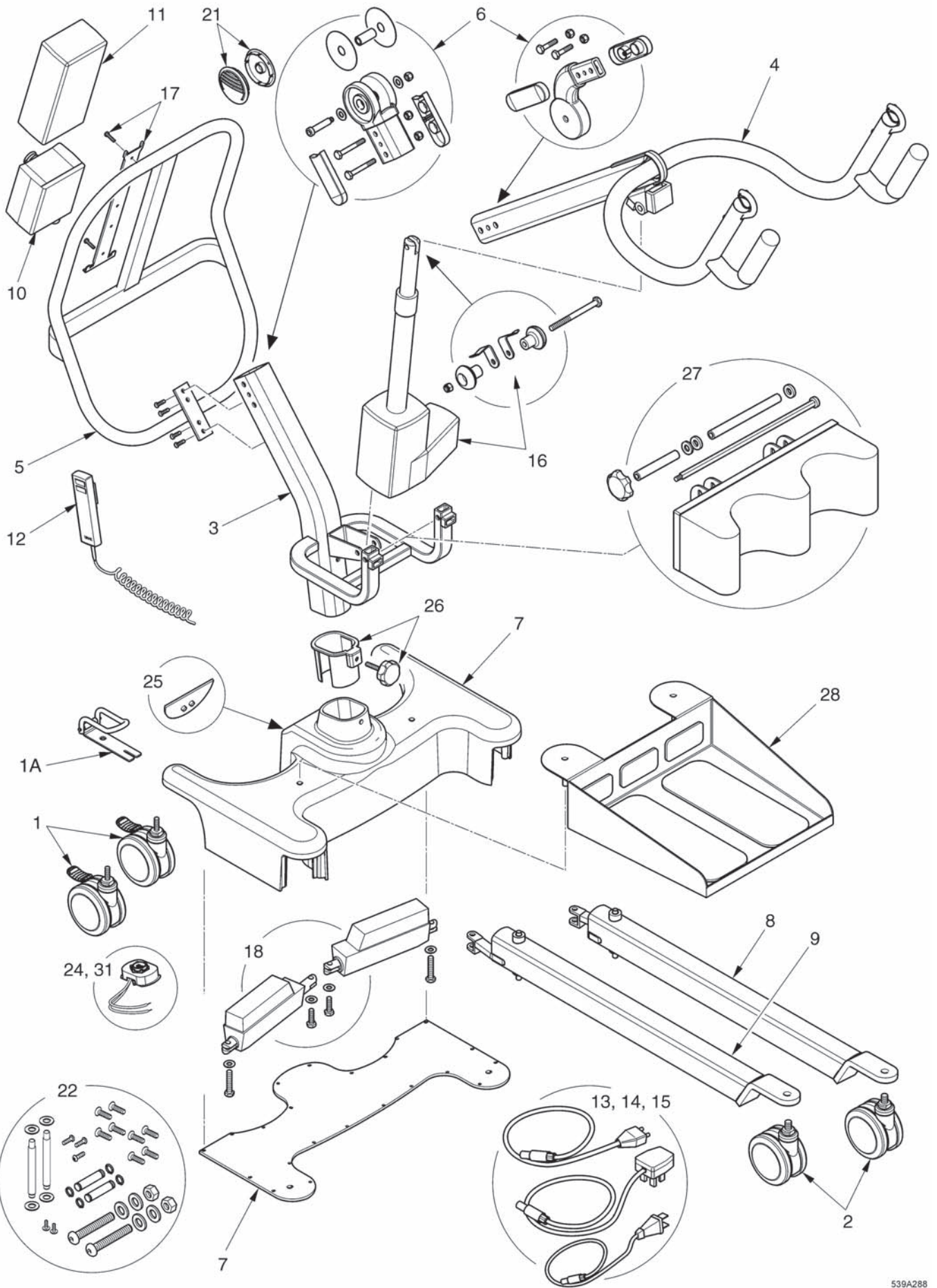

539A288

PARTS LIST (ARISE)

OXFORD / HOYER ARISE			
Nº	PART NUMBER	DESCRIPTION	QTY
1	0Y0066	100mm rear castor (braked)	2
1A	0Y0263	Straight-line steering device	1
2	0Y0073	100mm front castor (non braked) including tightening wrench (wrench not shown)	2
3	0Y0094	Mast extrusion including labels	1
4	0Y0095	Boom extrusion - Cow horn style (including boom end cap)	1
5	0Y0096	Push handle assembly (including bolts & fixings)	1
6	0Y0103	Casted boom to mast pivot joint (including connection bolts/fixings/spacers)	1
7	0Y0092	Base assembly (including labels, base casting and bottom plate, not internal parts)	1
8	0Y0099	Left leg extrusion (including fixings)	1
9	0Y0100	Right leg extrusion (including fixings)	1
10	0Y0353	Linak controller (4 way)	1
11	0Y0067	Linak battery	1
12	0Y0075	Linak hand control (4 way)	1
13	0Y0071	Linak charge lead (UK)	1
14	0Y0114	Linak charge lead (US)	1
15	0Y0072	Linak charge lead (EU)	1
16	0Y0097	Linak actuator - 310mm stroke (inc. location pins, sleeves, washers, nuts and labels)	1
17	0Y0069	Linak battery and controller brackets/fixings	1
18	0Y0093	Linak leg opening actuator - 35mm stroke (including bolts and fixings)	1
19	0Y0104	Decal set (Oxford) not shown - no serial number labels	1
20	0Y0098	Decal set (Hoyer) not shown - no serial number labels	1
21	0Y0126	Sunrise Pivot Caps	2
22	0Y0102	Fixings kit (all bolts, screws and fixings)	1
23	0Y0070	Handset clip (not shown)	2
24	0Y0077	Mast to base electrical connection kit (including wires)	1
25	0Y0078	Foot Push Pad assembly complete	2
26	0Y0112	Mast locking knob assembly (including plastic base insert)	1
27	0Y0105	Knee pad assembly (including all bolts and fixings)	1
28	0Y0101	Foot plate assembly	1
29	0Y0128	Castor tightening wrench (not shown)	1
30	0Y0053	Linak charger and stand assembly (not shown)	1
31	0Y0129	Base to actuator electrical connection kit (including wires)	1
32	0Y0108	Boom to mast pivot plastic caps	2
33	0Y0076	Mast side caps	2

EXPLODED VIEW (ASCEND)

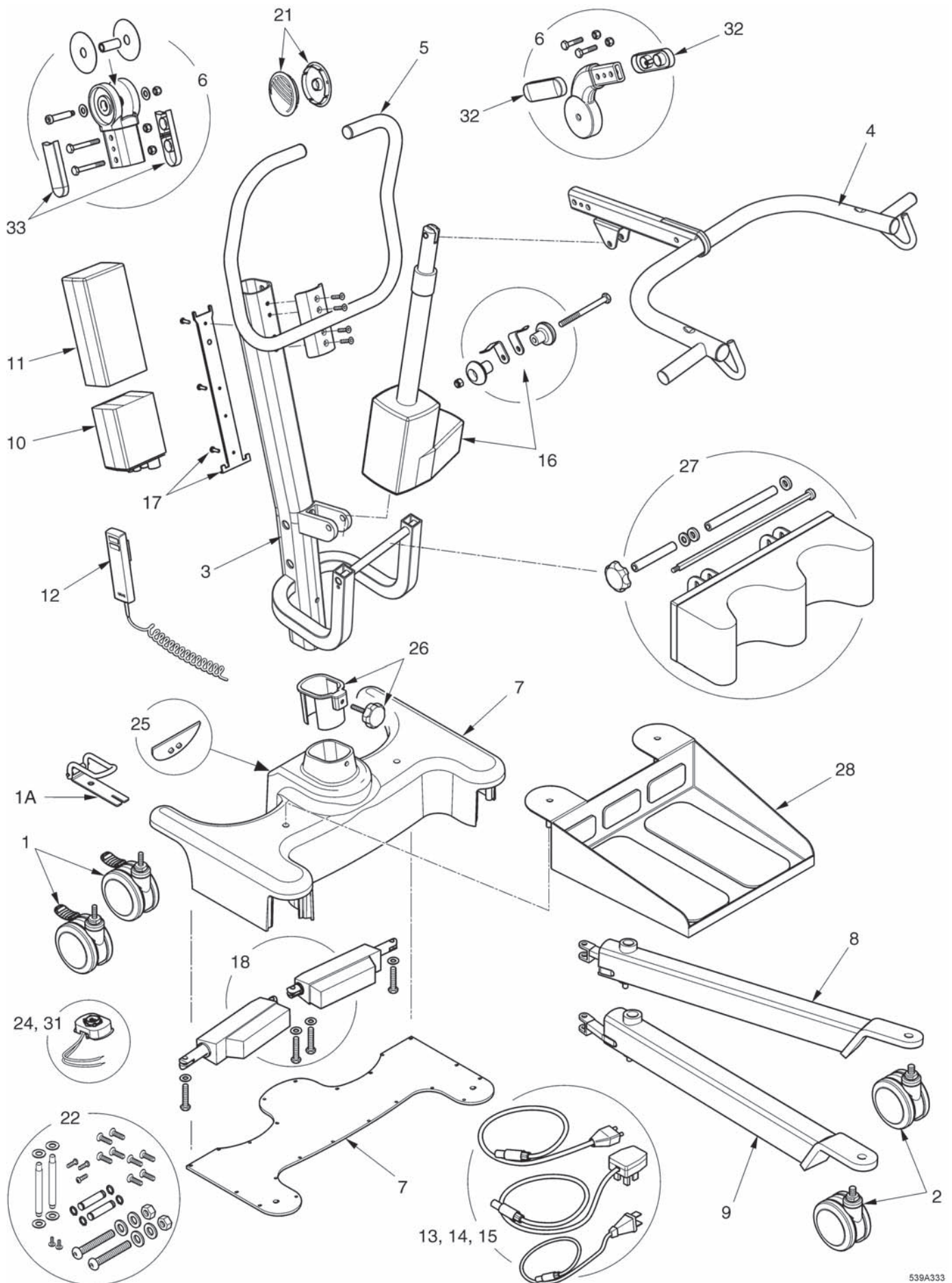

539A333

PARTS LIST (ASCEND)

OXFORD / HOYER ASCEND			
N°	PART NUMBER	DESCRIPTION	QTY
1	0Y0066	100mm rear castor (braked)	2
1A	0Y0263	Straight-line steering device	1
2	0Y0073	100mm front castor (non braked) including tightening wrench (wrench not shown)	2
3	0Y0206	Mast extrusion including labels 2006 MODEL*	1
	0Y0308	Mast extrusion including labels 2006/2007 MODEL*	1
4	0Y0207	Boom extrusion - Cow horn style (including boom end cap) 2006 MODEL*	1
	0Y0307	Boom extrusion - Cow horn style (including boom end cap) 2006/2007 MODEL*	1
5	0Y0208	Push handle assembly (including bolts & fixings)	1
6	0Y0103	Casted boom to mast pivot joint (including connection bolts/fixings/spacers)	1
7	0Y0092	Base assembly (including labels, base casting and bottom plate, not internal parts)	1
8	0Y0209	Left leg extrusion (including fixings)	1
9	0Y0210	Right leg extrusion (including fixings)	1
10	0Y0211	Linak controller (4 way)	1
11	0Y0067	Linak battery	1
12	0Y0075	Linak hand control (4 way)	1
13	0Y0071	Linak charge lead (UK)	1
14	0Y0114	Linak charge lead (US)	1
15	0Y0072	Linak charge lead (EU)	1
16	0Y0212	Linak actuator (inc. location pins, sleeves, washers, nuts, labels) 2006 MODEL*	0
	0Y0306	Linak actuator (inc. location pins, sleeves, washers, nuts, labels) 2006/2007 MODEL*	1
17	0Y0069	Linak battery and controller brackets/fixings	1
18	0Y0093	Linak leg opening actuator - 35mm stroke (including bolts and fixings)	1
19	0Y0213	Decal set (Oxford) not shown - no serial number labels	1
20	0Y0214	Decal set (Hoyer) not shown - no serial number labels	1
21	0Y0126	Sunrise Pivot Caps	2
22	0Y0102	Fixings kit (all bolts, screws and fixings)	1
23	0Y0070	Handset clip (not shown)	2
24	0Y0077	Mast to base electrical connection kit (including wires)	1
25	0Y0078	Foot Push Pad assembly complete	2
26	0Y0112	Mast locking knob assembly (including plastic base insert)	1
27	0Y0105	Knee pad assembly (including all bolts and fixings)	1
28	0Y0101	Foot plate assembly	1
29	0Y0128	Castor tightening wrench (not shown)	1
30	0Y0053	Linak charger and stand assembly (not shown)	1
31	0Y0129	Base to actuator electrical connection kit (including wires)	1
32	0Y0108	Boom to mast pivot plastic caps	2
33	0Y0076	Mast side caps	2

* Please check with Customer Services prior to ordering

LOLER: Thorough Examination Report

Lifting Operations and Lifting Equipment Regulations 1998 Schedule 1

Client Name & Address _____

_____ Tel _____

Address of Examination _____

Model _____ Serial No. _____ Date of Manu. _____

Date of last Examination _____ Safe Working Load _____

Commissioning Examination Yes No Safe to Operate Yes No N/A

Periodic Examination Yes No

Interval of Examination 6 Months 12 Months Examination Scheme Exceptional

Safe to Operate Yes No N/A

Defective Parts (Immediate Attention):

Part Number	Description	Defect	Action Taken

Defects requiring rectification at a later date:

Part Number	Description	Defect	Action Taken	Latest Date

Next examination due date _____

Load test conducted according to BS 5827 BS EN ISO 10535 Other (state) _____

Thorough examination carried out (Date) _____

Name of Examiner _____ Job Title _____

On behalf of (Company/Organisation) _____

Address _____

Signed _____

Signed on behalf _____

Date of Report _____

Name & address _____

NOTES



Sunrise Medical LTC Limited
High Street • Wollaston • Stourbridge
West Midlands • DY8 4PS • England
Tel +44(0)1384 44 66 22
Fax +44(0)1384 44 66 01
www.sunrisemedical.com

Sunrise Medical Inc
5001 Joerns Drive • Stevens Point
Wisconsin • 54481-5040 • England
Tel (715)341 3600
(800) 826 0270
www.sunrisemedical.com